

# The Crossbuck

a publication of the DuPage  
Division of the NMRA

Tim Schubert - Editor



## Fall - Winter 2012 Edition

### A MESSAGE FROM THE "SUP"

By Keith Lipske – Superintendent

As I write this we are a week away from our first meeting of the season. Alan has pretty much tied up all of the clinics for the year and as you know that is BIG!! Your BOD has been hard at work gearing up for the coming year which includes something we have never tried before.

What is it you ask? It's "**The Basics Of Building A Model Railroad**". This will be a seminar given by several of our members to people who are interested in building a model railroad but do not know where to begin. It will be given at the Downers Grove Park District facility in February 2013. Part of what the NMRA is all about is education. We need to show people what this hobby is all about. Not just running trains in circles but the fun that goes into building a miniature railroad. So there is nothing more fun and scary than stepping out of your

comfort zone and trying something new. Feel free to join in the fun!

Also I wanted to let you know that the All American Railroad Show was another success. **Thanks** to everyone that helped make it happen. It takes a great team to make this work as smoothly as it does..

It's **YOUR** Division!! **PARTICIPATE!!**

The "SUP"

### MEETING LOCATION FOR 2012-13

The Division meetings will be held at:

*St. Paul's United Church of Christ  
5729 Dunham Road  
Downers Grove, IL 60516*

The church is at the intersection of Dunham and Jefferson. There is plenty of parking and it is ADA accessible. Nearest major intersections:

North – 55<sup>th</sup> Street/Maple & Dunham

South – 63<sup>rd</sup> Street & Dunham

## **WELCOME NEW MEMBERS!**

By Ron Scharping – Membership Chairman

The following named individuals joined the NMRA and the DuPage Division since January 1, 2012. Welcome! Come to a meeting and say Hi.

Joe Bennett – Lisle, IL  
Richard Chapas – Plainfield, IL  
Kathleen Chapas – Plainfield, IL  
Tom Forst – LaGrange Park, IL  
Richard Grace – Naperville, IL  
Joseph Kaminskis – Joliet, IL  
Robert Knobbe – Glendale Heights, IL  
Donald Kopecky – St. Charles, IL  
Brian Krupicka – Lisle, IL  
Jeffery Large – Lockport, IL  
Lawrence McCoy – Wilmington, IL  
Mike McPherson – Wheaton, IL  
Richard Moser – Naperville, IL  
Fred Orcutt – Naperville, IL  
Fred Rossi – Channahon, IL  
William Schick – Chicago, IL  
Kim Schlytter – Lisle, IL  
Jeffery Scott – Chicago, IL  
Stephen Shelley – North Aurora, IL  
Richard Skinner – Montgomery, IL  
Richard Ulaszek – Plainfield, IL

## **2012-13 MEETING SCHEDULE**

### **September 9, 2012**

1:30pm at St. Paul's UCC

*Program: "Through the Artist Eyes" by Patrick Golden*

*Contest: Railroad cabooses, waycars, and any car with an End-of-Train device*

### **October 7, 2012**

1:30pm at St. Paul's UCC

*Program: DCC Roundtable Q&A by Bill Drzal, Wayne Pelker, Brian Barnt and Ron Scharping*

*Contest: Any bulk commodity car or covered hopper car to carry GRAIN. Also, any box car with the Signode wood plank grain doors*

### **November 4, 2012**

1:30pm at St. Paul's UCC

*Program: "Boy My Thumb is Green" by Ingrid Drozdek*

*Contest: National Model Railroad Month: Motive Power. Any locomotive decorated for a prototype or your private road.*

### **December 2, 2012**

1:30pm at St. Paul's UCC

*Program: Christmas Party*

*Contest: Holiday Season Photo Spectacular. Model or prototype in any color or B&W print, slide, or digital formats*

### **January 6, 2013**

1:30pm at St. Paul's UCC

*Program: "Pickle Factory for Your Layout" by Dave Leider*

*Contest: Water towers and depots. Scratchbuilt or kitbashed, bring something to showcase.*

### **February 3, 2013**

1:30pm at St. Paul's UCC

*Program: "TBA, but something entertaining" by Fred Henize*

*Contest: Express refrigerator cars and box cars equipped and designated for passenger trains – don't forget the steam lines.*

### **March 3, 2013**

1:30pm at St. Paul's UCC

*Program: "Progress on the Layout" by Tom Buller*

*Contest: Annual All Categories includes locomotives, freight and passenger cars, buildings, scenic vistas and photos.*

**March 2013** – The All American Railroad Show at Lyons Township High School – Date to be announced shortly!

### **April, 2013**

1:30pm at St. Paul's UCC

*Program: Division Layout Tours*

*Contest: No contest this month*

**May, 2013**

1:30pm at St. Paul's UCC

*Program:* "Colorado Railroading" by Grant Law

*Contest:* TBD – Any ideas are welcome!

\*Note: Dates may be subject to change

**DIVISION OFFICERS FOR 2012-13**

Superintendent – Keith Lipske

*Term expires 5/31/14*

Asst. Superintendent – Alan Basic

*Term expires 5/31/13*

Chief Clerk – Richard Strebendt

*Term expires 5/31/13*

Paymaster – Jim Allamian

*Term expires 5/31/14*

**Trainmasters** (All terms expire 5/31/13)

*Crossback Editor* – Tim Schubert

*All American Railroad Show Chairman* – Patrick Golden

*Membership Chairman* – Ron Scharping

*Achievement Program Chairman* – Rob Schiavone

*Contest Chairman* – Charlie Lewis

*Trainmaster* – Fred Henize

*Trainmaster* – Tom Buller

*Trainmaster* –

Additional Trainmaster positions are available, if you are interested in volunteering, please see the Superintendent or Assistant Superintendent.

Website: [www.mwr-nmra.org/dupage](http://www.mwr-nmra.org/dupage)

Division Address:

*DuPage Division – MWR – NMRA*

*P.O. Box 475*

*Downers Grove, IL 60516*

**A REPORT ON THE 2012 ALL AMERICAN RAILROAD SHOW**

By Patrick Golden – AARR Show Chairman

The Division had another successful All American Railroad Show this past March and was able to generate a grand total profit to the Division of \$1,801.18. In comparison, our three previous years generated profits

of \$1,866.13 in 2011, \$1,812.94 in 2010, and \$3,118.78 in 2009. The 2009 profit is a bit skewed because the Division also ran the concessions that year and added that profit of \$798.91 to the bottom line.

Our net gate (the take at the door after the money used to make change is deducted) was \$4,756.00 compared with \$5,645.75 in 2011, \$5,761.00 in 2010 and \$6,827.00 in 2009. Attendance at this year's show was down a bit as evidenced by the numbers, but a survey of the door prize registrations indicate we still draw from several outlying cities and towns and even a few from out of state.

Total expenses, which includes postage, office supplies, printing, advertising, coffee, donuts and lunches, came to \$1,915.09 compared with \$2,082.75 in 2011, \$2,400.76 in 2010 and \$2,261.07 in 2009. Expenses across the board can be expected to increase year to year with the biggest variance resulting from the number of lunches the Division provides to the exhibitors, but sometimes leftover office supplies from the previous year can be used and the total costs are offset somewhat.

Our contractual 50/50 split arrangement with the school resulted in a payment to the school of \$1,724.94 compared with \$1,781.50 in 2011, \$1,680.12 in 2010 and \$2,282.96 in 2009. A donation jar set out for coffee, donuts and lunches netted the Division an additional \$76.25 and a profit of \$304.84 from the concessions brought the Division's total profit to \$1,801.18.

The Division ran the concession for the first time in a few years, with the blessings of the school who even donated several cases of pop left over from their basketball season.

A big, big, thank you, to my wonderful wife Mary who took complete charge of the concessions and did a terrific job.

Our Division again had a table at the show and I need to send a heartfelt thank you to those who staffed it throughout the day. Kalmbach Publishing graciously donated three one-year subscriptions to *Model Railroader* magazine and the fine folks at the Illinois Railway Museum donated four family day passes to the museum. Our own Superintendent, Keith Lipske of Timberline Train Shop in Downers Grove again donated a train set. All eight prizes were awarded at the end of the day.

I need to send a sincere thank you to all the individuals who stepped up on the day of the show to collect money, stamp hands, count money, distribute lunches and do any number of other small tasks that I called upon them to do. Your willingness to help is very much appreciated.

I hope to have a date soon for the 2013 show and will again look to persuade the school to allow us to run the concessions.

And finally, if anyone in the Division knows of an individual or group who would like to exhibit at the show, please put me in touch with them. My goal has always been to put on the best show we can and one the public looks forward to and comes back to year after year.

### **FROM THE ACHIEVEMENT PROGRAM CHAIRMAN**

By Rob Schiavone

Here we are at the fall/winter issue of the Crossbuck and I am happy to report that members are continuing to apply for AP certification. By the time you read this Fred

Henize should have his AP certificate for Scenery. Bill Drzal will have an AP Certificate for Association Volunteer and Wayne Pelke has begun on the path with a Golden Spike Award. Congratulations gentleman! Here's a tip for those of you seeking MMR, if you present a clinic of thirty minutes or more with a handout you earn points for volunteer and for author.

In the last report I asked those who have received certificates in the past but did not go through me to send me information about their achievements. Paul Wussow was kind enough to give me a list of his. Paul has AP certificates in Association Volunteer, Model Railroad Engineer - Electrical, Model Railroad Author, Chief Dispatcher, and Model Railroad Engineer-Civil. He also has a Golden Spike. Just two more certificates to go Paul, to achieve Master Model Railroader.

Speaking of Master Model Railroaders, we have two in the DuPage Division. They are Palmer Kloster, MMR 104 and Jim Duffin, MMR 344. There are a total of 29 MMRs in the Midwest Region.

As I have stated before I am available for questions, even though I may not be able to get back to you right away. You can reach me at 630-690-3262 or at robert\_s\_60188@yahoo.com.

### **FROM THE BACK OF THE ROUNDHOUSE - Building the Railroad in Sections: The Perfect End Game**

By Charlie Lewis

For this clinic, "perfect" is obviously misleading as the only perfect thing in model railroading is the (my) First Law: "Anything installed and meant to be permanent will at some time have to be

relocated, rebuilt or re-something'd." That modular groups allow for moving things around is a good start. The prime advantage of a home layout built in sections; it can be moved when necessary. It also observes Dave Barry's rule: "Everything becomes portable as soon as it is carried."

Designing your layout in sections presents endless possibilities, each with their own set of surprises. Just a few basics gleaned from experience (mine and others) gets us started; at the far end of the next section to be built. So, follow the illustration shown below, for some ideas on sectional building.

This is one end of any section that you need. I call this the "D" end. It is the end section farthest from the central source of all wiring....have to start somewhere. Its mate on the next section is the "P" end. Both are 1"x3" and can also be 1"x2". The length should not exceed 24-30", else it all gets too wide (violating the "2-foot rule") and too heavy. A notch of 1"x 3/4" on each end is cut for attaching the section stringers which can nominally up to four feet in length. One or both notches can be flipped, (1) & (2).

Parts (A) are 1"x2" or 1"x3" blocks with a length of 2 inches that are cleats to hold one section level with the next especially when taking things apart. I agree with the experts who recommend that connector bolts be used for section alignment or load bearing. The cleats also help protect wiring between the sections. Part (B) is the inner side of the board and can be used to place terminal strips for wires and maybe a DCC booster. Part (C) has two holes (drilled 1/4") for 1/4" diameter carriage bolts that are 2 inches in length. Corresponding T-nuts are worked into the "D" end on the backside (end of the next section, which has no cleats). For less error two end boards are first clamped together to make a matched pair. Make sure that the cleats are correct, the top edges match and the bolt holes also line up. When not in use the bolts can be threaded

backwards through the T-nuts so that they do not get lost. Be sure to include the correct washers for the bolts.

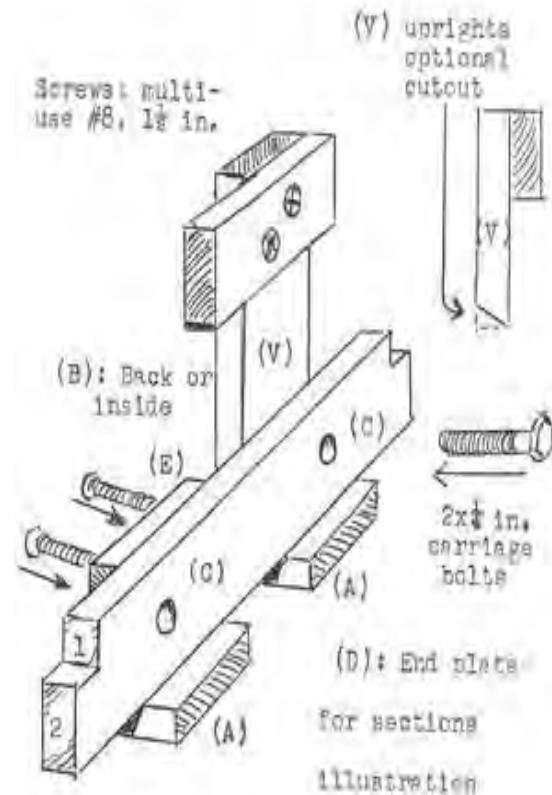

For Part (E) it is very important to keep the subroadbed from sagging (I use 1/4" plywood a lot). An extra cleat is added at track level using wood glue and screws as this is structural for level track. Cut 1"x1" or 1"x2" to the required length. Part (V) is the vertical support for any upper level tracks and is usually 1"x2" or 1"x3". The top 1"x2" has its partner on the next section correctly matched at the same time. Any number of these may be needed at different elevations. Screws that are no. 8 x 1-1/2" multi-purpose, flat head Phillips screws should be used.

These parts need to be built ahead of the installation date so the glue can dry fully. What glue? We all share the worst kept secret about wood; it splits. So to mitigate this problem, wet each end of the piece of

cut wood using a mist sprayer with a drop of dish soap. Now, work some glue into the end and let it dry. At the next session, the glue can be sanded and will now hold the screw forever, no split ends, no extra hard work or worry. The glue adds strength and is also a moisture block.

The additional technique is important because I get to quote John Ostler (NMRA Scale Rails, Aug 2004, pg 26): "The things I do (in his example, to produce a detailed HO freight car) resemble ART more than shop work." Railroads themselves are the near perfect expression of art. They have both motion and purpose and so do we railroad modelers. The joy of the hobby and the skills to get and keep trains running.

To be continued....

### **SHORT BLASTS (THINGS TO DO)**

By Tim Schubert – Crossbuck Editor

Some upcoming model railroading events for your calendar:

Oct 12 – Scale Model Railroad Swap Meet at Elmhurst Christian Reform Center sponsored by The Elmhurst Model RRC from 6pm to 9pm, admission \$5

Oct 12-31 – Pumpkin Train Rides on Waterman & Western at Waterman, IL Fri 5-9pm, Sat 2-9pm, Sun 2-8pm Free pumpkin for every passenger. [www.petestrain.com](http://www.petestrain.com)

Oct 13 - Fall Railroad Swap Meet & NYCS Movie Program at American Legion Post 66 in Griffith, IN. 12N – 5pm

Oct 13 & 14 – Southland Model Railroad Show at HL Richards HS in Oak Lawn Sat 10am-4pm, Sun 10am-3pm Adults \$6

Oct 14 – Joliet Union Station Centennial Banquet and Reception Advanced reservations required \$50 per person.

Oct 20 – Prairie Scale Model Railroaders Open House at 3 East Ash St, Lombard, IL from 7pm to 10pm

Oct 21 – St. Matthias Men's Club Train Show & Swap Meet in Crown Point, IN 10:30am to 3pm

Oct 18 to 20 – RPM Naperville Conference at Marriott Chicago-Naperville 1861 Naper Blvd, Naperville, IL see website for details.

Nov 4 – All Gauge Model Train Swap Meet at VFW Post 8141 in Calumet City, IL 10am to 2pm Admission \$3

Nov 23 – Prairie Scale Model Railroaders Open House at 3 East Ash St, Lombard, IL from 4pm to 8pm

Dec 1 – Semi-Annual Model Railroad Swap Meet at Stone City VFW Hall in Joliet, IL 9am to 3pm Admission: \$3

Jan 26 & 27 – Venture Crew 9911 BSA Rail-Rama 2013 at Charlestowne Mall in St. Charles, IL 10am–6pm & 11am–6pm Free

March 2013 – **All American Railroad Show at Lyon Township High School 31st Annual** - LaGrange, IL sponsored by the DuPage Division

March 9 & 10 – Highwheeler Model Railroad Show 2013 at Harper College Sports Center – Building M

Every Friday and Sunday – **Elmhurst Model Railroad Club Open House** Elmhurst, IL 7-10pm and 1-4pm

First Friday of each month – **Wagon masters Model Railroad Club Open House** Elmhurst, IL 7-10pm

Third Saturday of each month – **Bolingbrook MRRC meeting** – Community Center B at 201 Canterbury Lane in Bolingbrook, IL

See additional details on these events at [www.modelrailroader.com/events](http://www.modelrailroader.com/events).

If you know of any other events or are sponsoring an event, please let us know and we'll post it on the Division web site.

## NATIONAL & REGION NOTES AND INFORMATION

### FROM THE EDITOR

By Tim Schubert - Editor

Thank you to everyone that provided materials for this edition of the Crossbuck. As always, submissions are welcomed and encouraged from Division members. If you have an idea or thought to share, please consider sending in an article – short or long. Submissions can count towards your MMR achievements.

The **due date for submissions** the Winter-Spring 2013 Edition of the Crossbuck is **December 1, 2012**.

### GET THE ELECTRONIC CROSSBUCK

Receive the Crossbuck electronically by providing your email address to the Division. Advantages are that you can enjoy full color pictures (when included) and get the Crossbuck before anyone else. Emails are held as confidential and not shared with any organization. See the Editor or Ron Scharping to sign up today!

## CONTEST WINNERS FROM THE SEPTEMBER 2012 MEETING

*1<sup>st</sup> Place – Joe Bennett*



*2<sup>nd</sup> Place – Joe Bennett*



*3<sup>rd</sup> Place – Charlie Lewis*



**This edition of the Crossbuck is your notification for the October 7, 2012 Division Meeting.**

***The Crossbuck*** is the official publication of the DuPage Division of the National Model Railroad Association. Subscription is free to all NMRA members that reside within the boundaries of the DuPage Division. The DuPage Division does not offer any liability from the information contained within this publication.



The Crossbuck  
Official Publication of the DuPage Division  
of the National Model Railroad Association  
c/o Tim Schubert  
1278 Oxford Lane  
Wheaton, IL 60189